

# SMARTROLL® CUSTOM SPECIFICATIONS

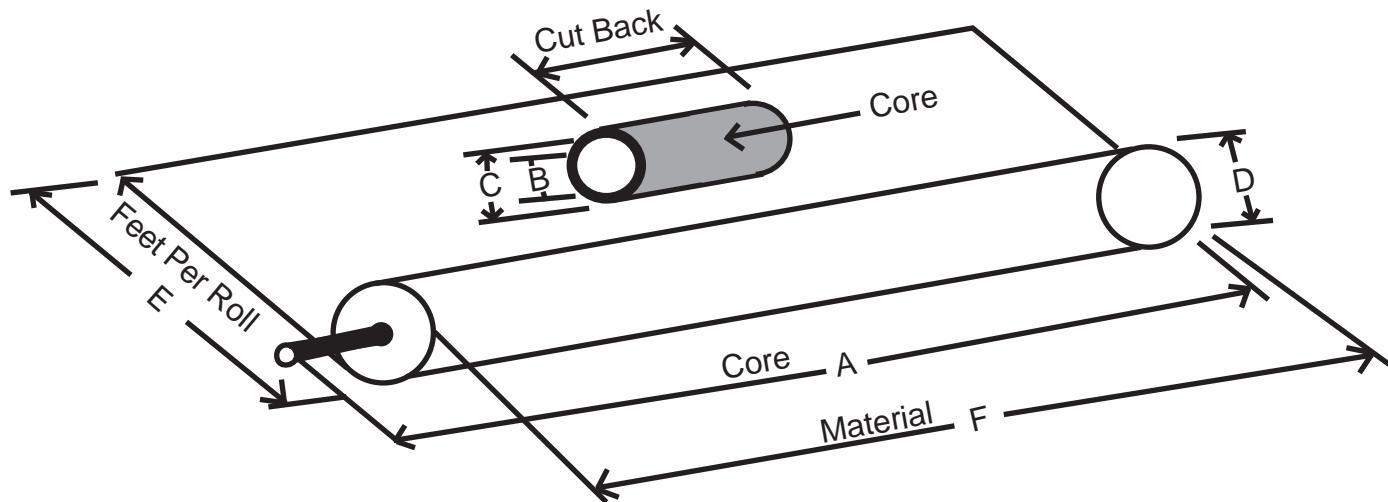

NAME: \_\_\_\_\_ DATE: \_\_\_\_\_

COMPANY: \_\_\_\_\_

ADDRESS: \_\_\_\_\_

CITY: \_\_\_\_\_ STATE: \_\_\_\_\_ ZIP CODE: \_\_\_\_\_

PHONE #: \_\_\_\_\_ FAX #: \_\_\_\_\_

SCREEN/STENCIL PRINTER: \_\_\_\_\_

EXPECTED MONTHLY USAGE: \_\_\_\_\_

**CORE:**

CORE LENGTH: "A": \_\_\_\_\_ (INCHES)

CORE I.D.: "B": \_\_\_\_\_ (INCHES)

CORE O.D.: "C": \_\_\_\_\_ (INCHES)

NOTCHES IN CORE: YES: \_\_\_ NO: \_\_\_

SPARE CORE: YES: \_\_\_ NO: \_\_\_

CORE MATERIAL: PAPER: \_\_\_ PLASTIC: \_\_\_

TAPE ON CORE: YES: \_\_\_ NO: \_\_\_

**MATERIAL:**

MAXIMUM ROLL O.D.: "D": \_\_\_\_\_ (INCHES)

\*FEET PER ROLL: "E": \_\_\_\_\_ (FEET)

\*FEET PER ROLL TOLERANCE IS +/- 10%

MATERIAL WIDTH: "F": \_\_\_\_\_ (INCHES)

TOTAL MATERIAL CUT BACK: \_\_\_\_\_ (INCHES)

IS ROLL CENTERED ON CORE: YES: \_\_\_ NO: \_\_\_

CUT BACK: RIGHT: \_\_\_ (INCHES) / LEFT: \_\_\_ (INCHES)

MATERIAL SENSOR WINDOW: YES: \_\_\_ NO: \_\_\_

<b>SELECT PRIORITY:</b>
_____
_____

**ADDITIONAL INFORMATION:**

\_\_\_\_\_  
\_\_\_\_\_  
\_\_\_\_\_

CUSTOMER SIGNATURE: \_\_\_\_\_

NOTE: CUSTOM PRODUCT ORDERS CANNOT BE CANCELLED OR RETURNED